



## GEMSTONE TOWER BASIN MIXER

### DESCRIPTION

Gemstone Tower Basin Mixer

### FEATURES

- Modern 2 tone finish
- Superior design German technology recessed housing-less aerator
- Continuous alignment of body and spout
- Solid brass construction
- Sleek design encompassing the latest up-to-date ceramic disc cartridge technology
- 10 year limited domestic warranty on mixer body, cartridge and chrome finish, 5 years on coloured finishes

## DETAILS

35mm cartridge

WELS 3 star 8L/m, RN: T25533

Part Code: AG-103

Available Finish: White / Chrome

Recommended working pressure:

Min 150 – Max 500KPa

Note: If the pressure exceeds or is likely to exceed 500KPa, an approved pressure limiting device must be fitted.

Maximum hot water temperature 80°

## TECHNICAL DETAILS

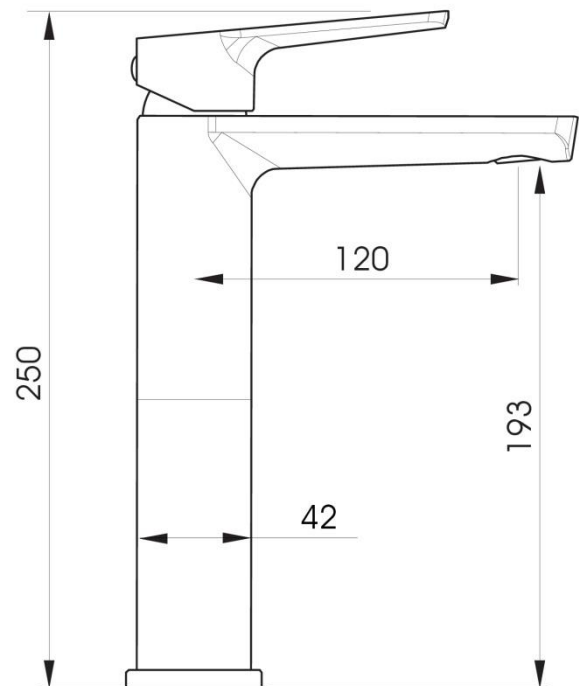

Note: Illustrations and specifications may vary from time to time